

- UART
- UART TX RX
- Dim+ 200-450uA 12V
- DIM + GND 36k

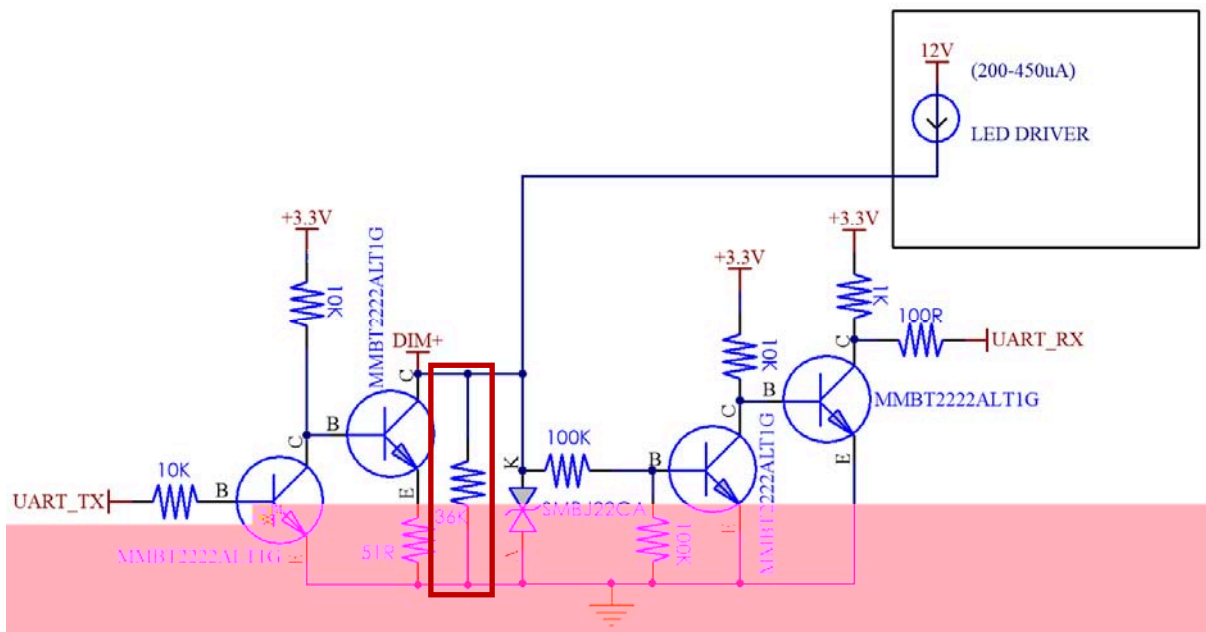

- NB-IOT GPRS 4G , 400mA.

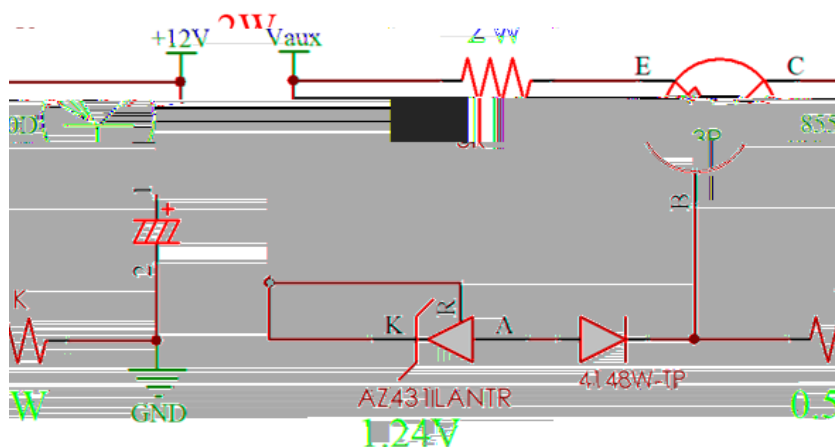

- UART
- 1 8 1
- 9600
- 60ms 100ms

- 2
- = + + +

-
- ○
-
- ○
-
- ○
-
- ○ AD 1
-
- ○ NTC AD 2
-
- ○
-
- ○
-
- ○

UART

100ms

2

2

= + + +

0x3A	0x31	0x00	0x01	0x00-0x64	0x0D	0x0A			
	0x32	0x00	0x01	0x55,					
	0x3A	0x00	0x01	0x02					
		0x01	0x01	0x02					
		0x03	0x01	0x01					AD
		0x04	0x01	0x01					AD
	0x3B	0x00/0x01	0x02	2					/
	0x3C	0x00	0x01	0x00-0xC8					
	0x3D	0x00	0x01	0x55,					
	0x35	0x0B	0x01	0x05			0x46		
	0x36	0x0B	0x05	5					
	0x35	0x20	0x01	0x01			0x57		
0x36	0x20	0x01	1						

•

LED

()

EEPROM

0x3C

70% (70= 0x46)

0x3A	0x31	0x00	0x01	0x46	0x78	0x0D	0x0A

EUD - 200SxxxDxA	1743
EUD - 240SxxxDxA	1803
ESD - 480SxxxDx	/

YYWW

PRG-MUL2

" "

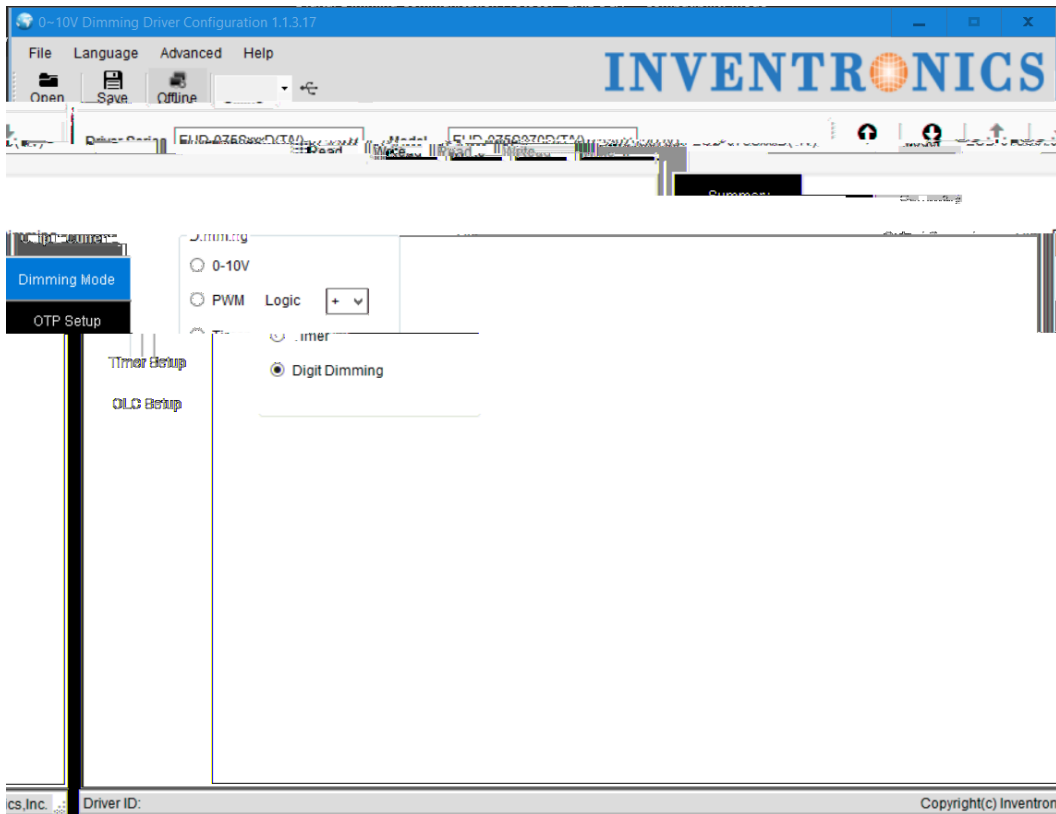

OTP: AD

15	125	55	76	95	54	135	38	175	23	215	4
16	123	56	75	96	54	136	38	176	22	216	4
17	121	57	74	97	53	137	37	177	22	217	3
18	118	58	74	98	53	138	37	178	22	218	2
19	116	59	73	99	52	139	37	179	21	219	2
20	114	60	72	100	52	140	36	180	21	220	1
21	112	61	72	101	52	141	36	181	20	221	0
22	111	62	71	102	51	142	36	182	20	222	0
23	109	63	71	103	51	143	35	183	20	223	-1
24	107	64	70	104	50	144	35	184	19	224	-2
25	105	65	69	105	50	145	34	185	19	225	-2
26	104	66	69	106	50	146	34	186	18	226	-3
27	103	67	68	107	49	147	34	187	18	227	-4
28	101	68	68	108	49	148	33	188	17	228	-5
29	100	69	67	109	48	149	33	189	17	229	-5
30	98	70	66	110	48	150	33	190	17	230	-6
31	97	71	66	111	47	151	32	191	16	231	-7
32	96	72	65	112	47	152	32	192	16	232	-8
33	95	73	65	113	47	153	31	193	15	233	-9
34	94	74	64	114	46	154	31	194	15	234	-10
35	93	75	64	115	46	155	31	195	14	235	-11
36	91	76	63	116	45	156	30	196	14	236	-12
37	90	77	63	117	45	157	30	197	13	237	-13
38	89	78	62	118	45	158	29	198	13	238	-14
39	88	79	62	119	44	159	29	199	13	239	-15
40	88	80	61	120	44	160	29	200	12	240	-16
41	87	81	61	121	44	161	28	201	12	241	-17
42	86	82	60	122	43	162	28	202	11	242	-18
43	85	83	60	123	43	163	28	203	11	243	-20
44	84	84	59	124	42	164	27	204	10	244	-21
45	83	85	59	125	42	165	27	205	10	245	-23
46	82	86	58	126	42	166	26	206	9	246	-25
47	82	87	58	127	41	167	26	207	9	247	-27
48	81	88	57	128	41	168	26	208	8	248	-29
49	80	89	57	129	40	169	25	209	7	249	-31
50	79	90	56	130	40	170	25	210	7	250	-34
51	78	91	56	131	40	171	24	211	6	251	-38
52	78	92	56	132	39	172	24	212	6	252	-40
53	77	93	55	133	39	173	24	213	5		
54	76	94	55	134	39	174	23	214	5		

	OTP: AD			OTP				10K			
1	20	46	1122	91	2830	136	5829	181	12474	226	39745
2	40	47	1152	92	2879	137	5921	182	12715	227	41346
3	61	48	1183	93	2928	138	6015	183	12963	228	43067
4	81	49	1213	94	2978	139	6111	184	13217	229	44919
5	102	50	1244	95	3028	140	6209	185	13479	230	46920
6	123	51	1275	96	3079	141	6308	186	13748	231	49088
7	144	52	1306	97	3131	142	6409	187	14025	232	51443
8	165	53	1338	98	3183	143	6512	188	14310	233	54014
9	187	54	1370	99	3237	144	6616	189	14605	234	56829
10	208	55	1403	100	3290	145	6723	190	14908	235	59925
11	230	56	1435	101	3345	146	6831	191	15220	236	63347
								192	15543	237	67150
								193	15876	238	71400
								194	16220	239	76181
								195	16575	240	81600
								196	16942	241	87793
								197	17322	242	94938
								198	17716	243	103275
								199	18123	244	113127
								200	18545	245	124950
								201	18983	246	139400

41	977	86	2595	131	5388	176	11362	221	33150		
42	1006	87	2641	132	5473	177	11573	222	34309		
43	1034	88	2687	133	5560	178	11790	223	35541		
44	1064	89	2734	134	5648	179	12012	224	36852		
45	1093	90	2782	135	5738	180	12240	225	38250		

LED

2018-12-20	A		/	/
2019-01-31	B		/	
2019-04-08	C	-	/	
			/	
2019-05-22	D		ESD - 480SxxxD x	